

HANDRAIL STANDARDS



**Global
Walkway
Solutions**

TO: _____ REF: _____ DATE: _____

Please tick appropriate boxes and fill in relevant dimensional information

TYPES OF BASE

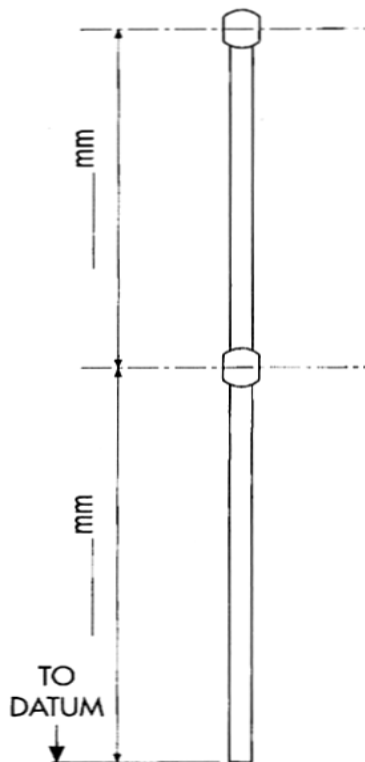

- NUMBER REQUIRED _____
- SHANK DIAMETER _____ mm
- BALL DIAMETER _____ mm
- DRILLED TO SUIT _____ mm DIAMETER HANDRAIL
- BASE THICKNESS (Refer DIM.A):
 12mm 15mm
 OTHER _____
- PRE VENTED YES NO
- FINISH -
 SELF COLOUR RED OXIDE
 GALVANISED OTHER Please specify: _____

<p>RECTANGULAR FLAT BASE <input type="checkbox"/></p>	<p>HORIZONTAL SIDE PALM <input type="checkbox"/></p>
<p>CIRCULAR FLAT BASE <input type="checkbox"/></p>	<p>LONG PALM <input type="checkbox"/></p>
<p>OFFSET PALM <input type="checkbox"/></p> <p>OFFSET X = _____</p>	<p>TRIANGULAR SIDE PALM <input type="checkbox"/></p>
<p>FIXING HOLES TO BE 18mm DIAMETER U.N.O. NO BASE REQUIRED (STICK ONLY) <input type="checkbox"/></p>	

COMMENTS

RAKED HANDRAIL STANDARDS

TO:

REF:

DATE:

Please tick appropriate boxes and fill in relevant dimensional information

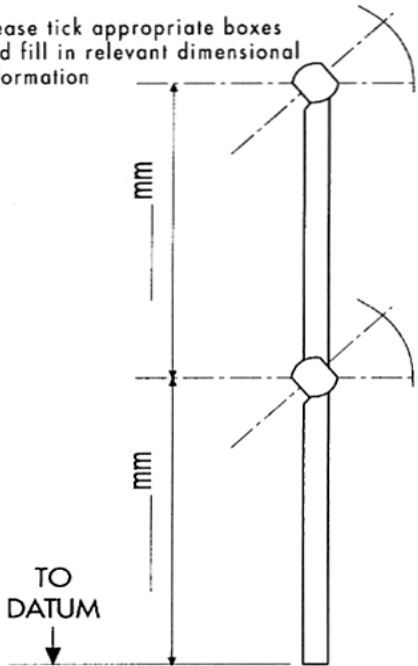

- NUMBER REQUIRED _____
- RAKED AT _____ DEGREES
(WHEN _____ NUMBER L/HAND APPLICABLE) _____ NUMBER R/HAND
- SHANK DIAMETER _____ mm
- BALL DIAMETER _____ mm
- DRILLED TO SUIT _____ mm
DIAMETER HANDRAIL
- BASE THICKNESS (Refer DIM.A):
 12mm 15mm
 OTHER _____
- PRE VENTED YES NO
- FINISH -
 SELF COLOUR RED OXIDE
 GALVANISED OTHER Please specify: _____

TYPES OF BASE

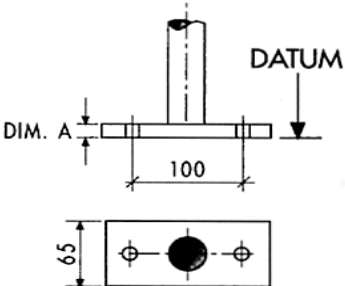
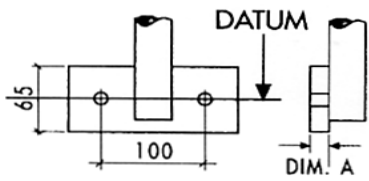
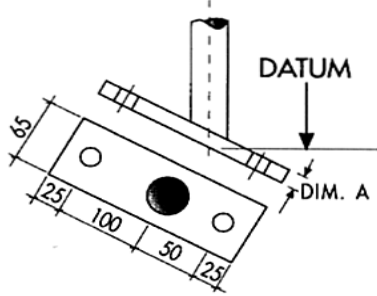
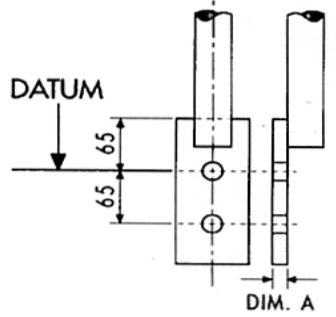
<p>RECTANGULAR FLAT BASE <input type="checkbox"/></p> 	<p>HORIZONTAL SIDE PALM <input type="checkbox"/></p> 
<p>RECTANGULAR RAKED FLAT BASE <input type="checkbox"/></p> 	<p>LONG PALM <input type="checkbox"/></p> 
<p>FIXING HOLES TO BE 18mm DIAMETER U.N.O.</p> <p>NO BASE REQUIRED (STICK ONLY) <input type="checkbox"/></p>	

COMMENTS



HANDRAIL SECTIONS

**Global
Walkway
Solutions**

TO: _____

REF: _____

DATE: _____

RETURN BEND

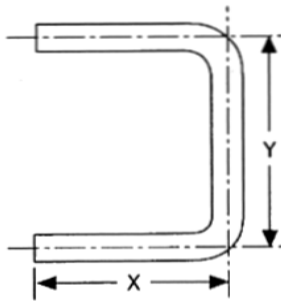

- NUMBER REQUIRED _____
- DIM. X _____ mm
- DIM. Y _____ mm

STAIR RETURN BEND

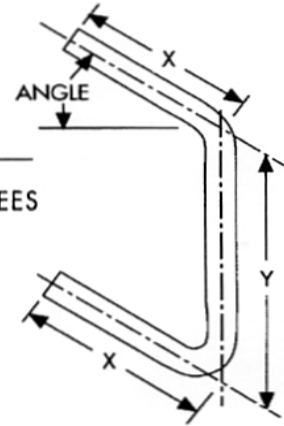

- NUMBER REQUIRED _____
- RAKED AT _____ DEGREES
- DIM. X _____ mm
- DIM. Y _____ mm

RAMP BEND

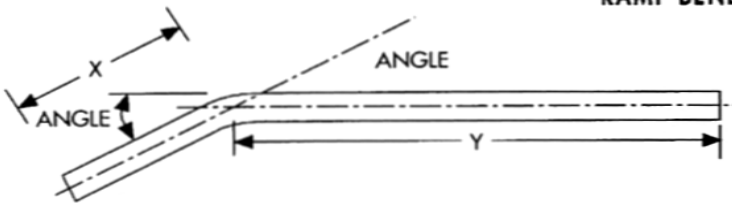

- NUMBER REQUIRED _____
- RAKED AT _____ DEGREES
- DIM. X _____ mm
- DIM. Y _____ mm

RIGHT ANGLE BEND 90 DEGREES

- NUMBER REQUIRED _____
- DIM. X _____ mm
- DIM. Y _____ mm

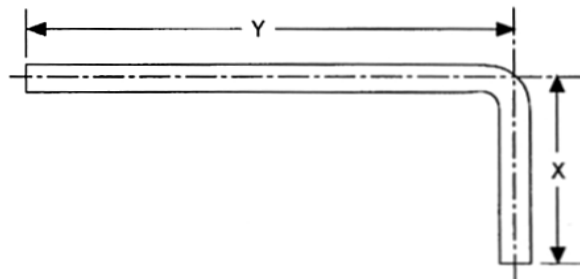

COMMENTS



HANDRAIL SECTIONS

**Global
Walkway
Solutions**

TO: _____ REF: _____ DATE: _____

SIMPLE WREATH - LEFT HAND GOING UP

- NUMBER REQUIRED _____
- RAKED AT _____ DEGREES
- DIM. X _____ mm
- DIM. Y _____ mm
- DIM. Z _____ mm

SIMPLE WREATH - RIGHT HAND GOING UP

- NUMBER REQUIRED _____
- RAKED AT _____ DEGREES
- DIM. X _____ mm
- DIM. Y _____ mm
- DIM. Z _____ mm

DUAL FLIGHT - LEFT HAND GOING UP WREATH RETURN

- NUMBER REQUIRED _____
- RAKED AT:
 - ANGLE A _____ DEGREES
 - ANGLE B _____ DEGREES
- DIM. X _____ mm
- DIM. Y _____ mm
- DIM. Z _____ mm

DUAL FLIGHT - RIGHT HAND GOING UP WREATH RETURN

- NUMBER REQUIRED _____
- RAKED AT:
 - ANGLE A _____ DEGREES
 - ANGLE B _____ DEGREES
- DIM. X _____ mm
- DIM. Y _____ mm
- DIM. Z _____ mm

COMMENTS

OPEN STEEL STAIR TREADS



**Global
Walkway
Solutions**

TO: _____ REF: _____ DATE: _____

Please tick appropriate boxes and fill in relevant dimensional information

- NUMBER REQUIRED _____
- LOAD BEARING BAR SECTION (E.G. 25 x 3mm) _____ mm
- BEARING BAR/CROSS BAR ARRANGEMENT (E.G. 41/100mm) _____ mm
- LENGTH (DIM. A) _____ mm
- WIDTH (DIM. B) _____ mm

TYPES OF TREAD

OPEN TREAD

NOSING BAR TYPE = OCTOPUS DIMPLE OTHER _____

DIAMOND TREAD

NOSING BAR TYPE = OCTOPUS DIMPLE OTHER _____

N.B. - BEARING BAR/CROSS BAR ARRANGEMENT IS 41/178mm ON DIAMOND PATTERN

LADDER TREAD

END PLATE DETAIL
 OPEN TREAD/DIAMOND TREAD - 14mm DIA. HOLES
 SLOT 14mm X 40mm
 LADDER TREAD ONLY - 12mm DIA. HOLES

OPEN TREAD/DIAMOND TREAD

END PLATE HOLE CENTRES

- DIM. C 100mm 112mm 125mm

LADDER TREAD ONLY

END PLATE HOLE CENTRES

- DIM. C 50mm 75mm

FINISH

- SELF COLOUR
- GALVANISED
- RED OXIDE
- OTHER

PLEASE SPECIFY _____

COMMENTS

FABRICATED OPEN STEEL FLOORING



**Global
Walkway
Solutions**

TO: _____ REF: _____ DATE: _____

Please tick appropriate boxes and fill in relevant dimensional information

- LOAD BEARING BAR SECTION (E.G. 25 x 3mm) _____ mm
- BEARING BAR/CROSS BAR ARRANGEMENT (E.G. 41/100mm) _____ mm
- FINISH SELF COLOUR GALVANISED
 RED OXIDE OTHER PLEASE SPECIFY

No. REQ'D	LENGTH DIM. A	WIDTH DIM. B

PANEL TYPES

RECTANGULAR PANELS

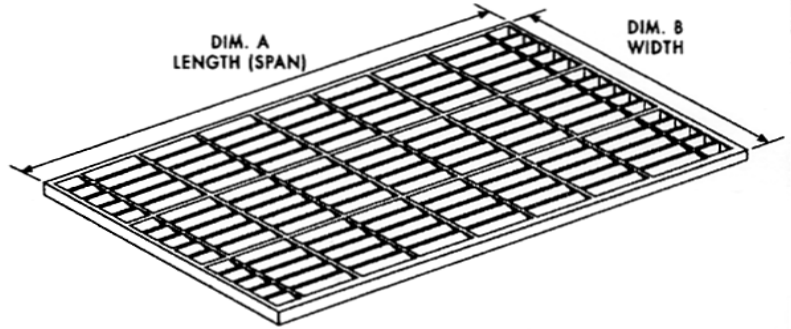

- LOAD BEARING BAR SECTION (E.G. 25 x 3mm) _____ mm
- BEARING BAR/CROSS BAR ARRANGEMENT (E.G. 41/100mm) _____ mm
- FINISH SELF COLOUR GALVANISED
 RED OXIDE OTHER PLEASE SPECIFY

No. REQ'D	DIAMETER mm

CIRCULAR PANELS

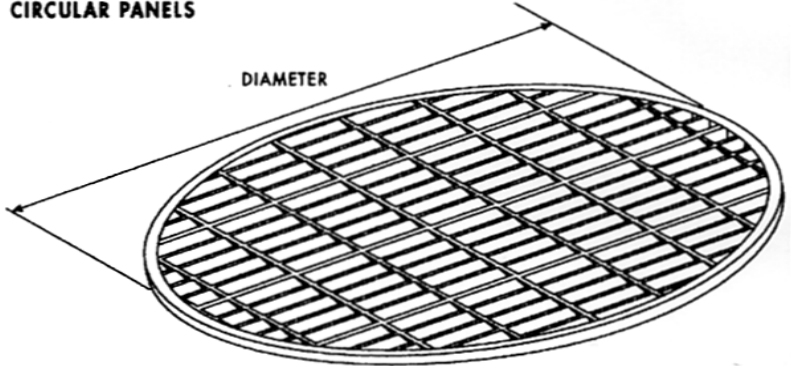

- LOAD BEARING BAR SECTION (E.G. 25 x 3mm) _____ mm
- BEARING BAR/CROSS BAR ARRANGEMENT (E.G. 41/100mm) _____ mm
- FINISH SELF COLOUR GALVANISED
 RED OXIDE OTHER PLEASE SPECIFY

No. REQ'D	LENGTH DIM. A

SQUARE PANELS

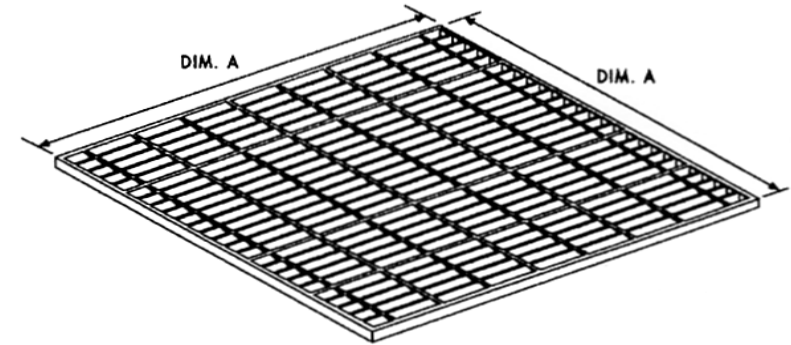

COMMENTS